

# DECKS

## City of Lawrence

Department of Public Works  
317-545-8787  
[www.cityoflawrence.org](http://www.cityoflawrence.org)

This handout is intended only as a guide to the subject matter covered herein and is based in part on the 2020 Indiana Residential Code. While every attempt has been made to ensure the correctness of this handout, no guarantees are made to its accuracy or completeness. Responsibility for compliance with applicable codes and ordinances falls on the owner or contractor. For specific questions regarding code requirements, refer to the Indiana Building Code or contact your local Building Department.

### PERMITS

A building permit is required to construct a deck measuring 200 square feet or larger or if the deck is more than 30 inches off the ground.

In addition to the City of Lawrence permit you will also be required to obtain an Improvement Location Permit from the Department of Business and Neighborhood Services in Marion County. Please visit their website at <https://www.indy.gov/activity/residential-development-permits> for more information.

### PLANS

Plans must include a site plan, construction plans, elevation drawings, framing plan, ledger details, footing details, stair and guard details. See the checklist for deck plans provided later in this document.

The following are examples of information that should be included on plans submitted for building permits for residential decks. They are examples only and should not be construed as being code compliant for every application. It is the responsibility of the homeowner or person preparing the plans to show in detail how they will build their deck. Some designs may require more detail than others. Your deck plans should replicate exactly how you will build your deck. We will review your plans before we issue the building permit to identify code violations before you start work. The more detailed your plans, the more likely you avoid corrections in the field.

Once your plans are released, you should not change your design without approval by the Department of Public Works. You should read through the released plans to determine if the plan reviewer noted any corrections to your plan. If you have any questions regarding any of the corrections, you should contact us before proceeding.

*Plans created at home centers are seldom acceptable for plan review.* These computer designs do not allow homeowners to duplicate conditions at their home. Applications submitted with these types of plans will be returned to the applicant.

### INSPECTIONS

Call 317-545-8787 at least 24-48 hours in advance and have address, permit number, and type of inspection (ex. footing) ready.

- Footing Inspection - Holes dug, loose material/water removed and reinforcement installed if required.
  - Plans and permit card on-site.
- Final Inspection - All work complete and all stairs, handrails, and guards in place.
  - Plans and permit card along with the installation instructions for composite decking on-site.

If work is found in compliance with code, the inspector will sign the permit and you may proceed with the next step.

If corrections are noted, an Inspection Report will be left on the site. If a re-inspection is required it will be noted on the Inspection Report.

### THINK YOU MIGHT ENCLOSE YOUR DECK IN THE FUTURE?

Deck plans are released on the assumption that the deck will be used only as a deck for the life of the structure. Because footing sizes, setbacks, structural supports, and a host of other deck components are different for enclosed porches than for decks, it is important that you indicate on your plans the desire to convert the deck at a future date. You should then design your deck to carry future loads and meet setbacks and other rules.

---

## TERMINOLOGY

1. RAIL TOP CAP
2. BALLUSTERS
3. RAIL POST
4. SUPPORT POST
5. RIM OR BAND JOIST
6. DECKING
7. JOISTS
8. POST BASE CONNECTOR
9. PIER
10. FOOTING
11. DROP BEAM
12. BLOCKING
13. HOUSE JOIST
14. ½" BOLTS
15. LEDGER BOARD
16. FLASHING



---

## MATERIALS

### Fasteners

Nails and other hardware must be hot-dipped zinc-coated (galvanized), stainless steel or equal. Screws should be either hot-dipped galvanized or electroplated with a polymer coating. 12d nails are recommended on nominal 2-inch decking. 10d nails are recommended for 5/4" decking.

With lag screws, use a flat washer under the head. Use washers under the nut and head of machine bolts and just under the nut of carriage bolts.

### Lumber

All wood used in deck construction must be pressure treated lumber or wood that is naturally resistant to decay such as redwood or cedar.

Wood used above ground, in contact with the ground, or below ground requires different degrees of treatment. Check the labels of the material you are buying to determine where it can be used. Because some preservative

treatments are very corrosive, make sure that any fasteners or metal connectors used in the construction of your deck are approved by the manufacturer for use with treated wood.

Decking

Materials commonly used for decking include standard dimension lumber (either 2X4 or 2X6), radius-edged decking, or a manufactured decking product.

Radius-edged Patio Decking (5/4 decking) has been specifically developed for outdoor decks. Redwood and cedar patio decking is intended to be used flat-wise in load-bearing applications where spans do not exceed 16" o.c. (12" o.c. when installed diagonally to joists). Southern pine decking may span 24" o.c. or 16" o.c. when installed diagonally to joists.

Manufactured decking products may be used only when the material is allowed by an NER or similar report. Decking without a research report will not be allowed. Ask the decking supplier to provide you with a copy of the research report. The Building Department maintains a list of composite decking materials that meet US building codes that is available upon request. Caution – some manufactured deck products are approved for decking but not for stair treads. In some cases where manufactured decking is approved for stairs, the spacing of supports may be significantly reduced compared to use on the deck itself. Refer to our Composite Decking handout for further information.

MAXIMUM DECK BOARD SPANS	
2x6 OR 5/4 SOUTHERN PINE PERPENDICULAR TO JOIST	24" O.C.
5/4 CEDAR OR REDWOOD AND 2X4 PERPENDICULAR TO JOIST OR 5/4 SOUTHERN PINE OR 2X6 AT 45 DEGREES TO JOIST	16" O.C.
5/4 AND 2X4 AT 45 DEGREE TO JOIST	12" O.C.

Footings

Be sure you call 811 at least 72 hours prior to digging!!!



Footings supporting a 4x4 column must be not less than 6-inch diameter. Post footings supporting columns larger than 4x4 must be 8-inch diameter or larger. The bottom of post footings may be “belled” to achieve the desired minimum bearing area. The base of the footing must be at least 30 inches below finished grade. Rebar is recommended. Center the column on the footing secured by a pin or connector. Posts imbedded in the ground must be 60% C.C.A. or equal. Using a fiberboard tube will allow elevation of the top of the footing above finished grade to provide protection of the wood post from lawn mowers and trimmers.

## UNDERSTANDING LOAD PATHS

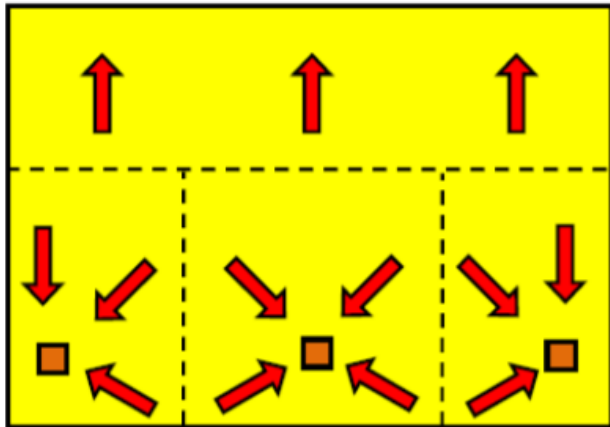

Loads are assumed to be uniform across the floor

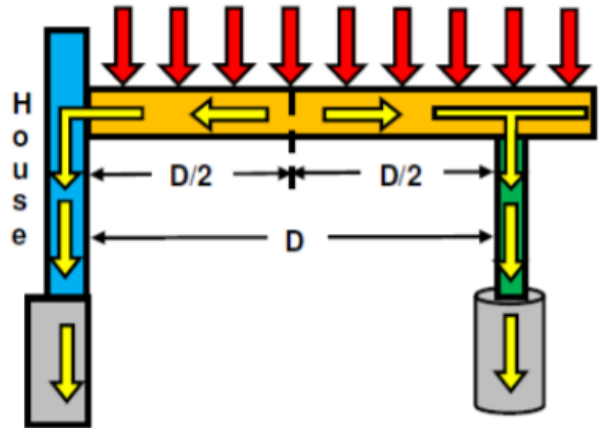

Deck footings should be sized according to the following table. Footings must extend at least 30 inches below grade (frost line) except for decks that are not connected to a dwelling.

TABLE R507.3.1  
MINIMUM FOOTING SIZE FOR DECKS

LIVE OR GROUND SNOW LOAD <sup>b</sup> (psf)	TRIBUTARY AREA (sq. ft.)	LOAD BEARING VALUE OF SOILS <sup>a, c, d</sup> (psf)											
		1500 <sup>e</sup>			2000 <sup>e</sup>			2500 <sup>e</sup>			≥ 3000 <sup>e</sup>		
		Side of a square footing (inches)	Diameter of a round footing (inches)	Thickness (inches)	Side of a square footing (inches)	Diameter of a round footing (inches)	Thickness (inches)	Side of a square footing (inches)	Diameter of a round footing (inches)	Thickness (inches)	Side of a square footing (inches)	Diameter of a round footing (inches)	Thickness (inches)
40	20	12	14	6	12	14	6	12	14	6	12	14	6
	40	14	16	6	12	14	6	12	14	6	12	14	6
	60	17	19	6	15	17	6	13	15	6	12	14	6
	80	20	22	7	17	19	6	15	17	6	14	16	6
	100	22	25	8	19	21	6	17	19	6	15	17	6
	120	24	27	9	21	23	7	19	21	6	17	19	6
	140	26	29	10	22	25	8	20	23	7	18	21	6
160	28	31	11	24	27	9	21	24	8	20	22	7	

Required footing sizes are determined by calculating the area of the deck supported by each footing. Loads shall be assumed to be equally shared between the supporting elements. Don't overlook cantilevers.

### THE REQUIRED AREA OF THE COLUMN SHOULD FULLY BEAR ON THE FOOTING

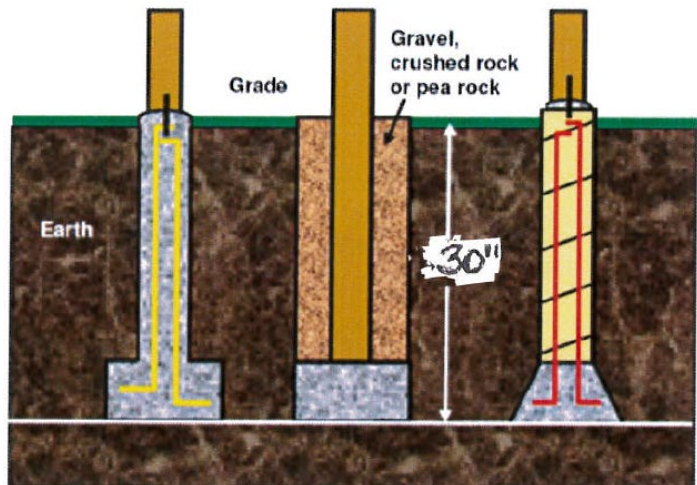
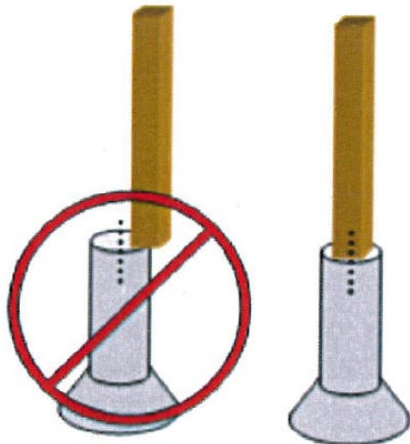



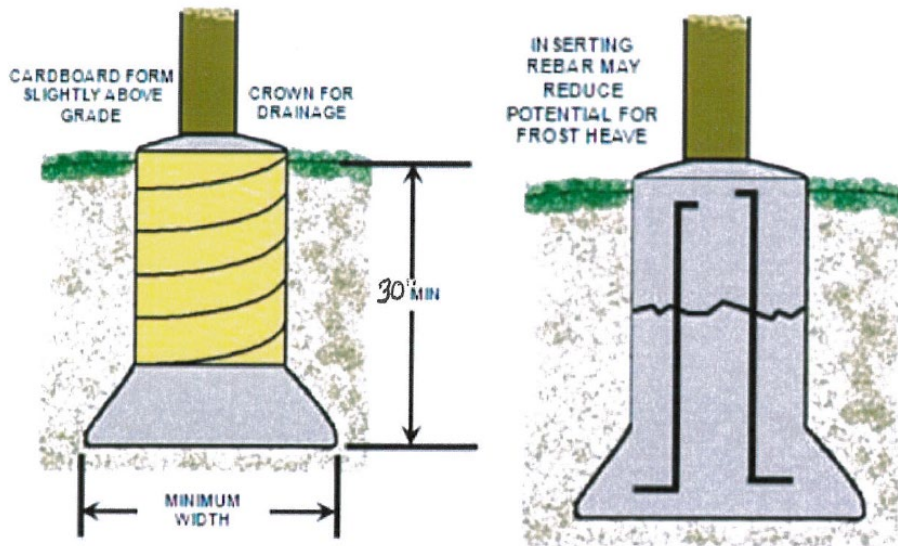

### WHERE DO I PUT MY FOOTINGS?

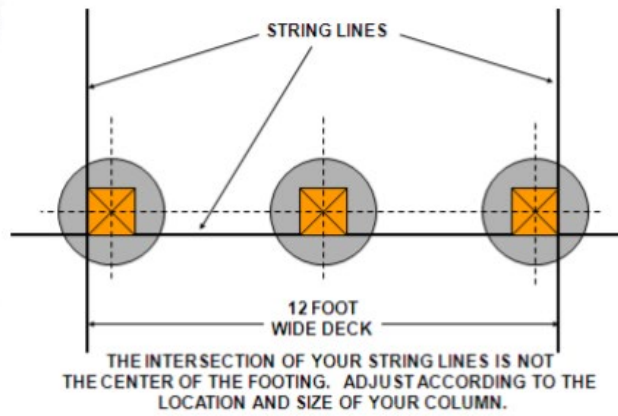
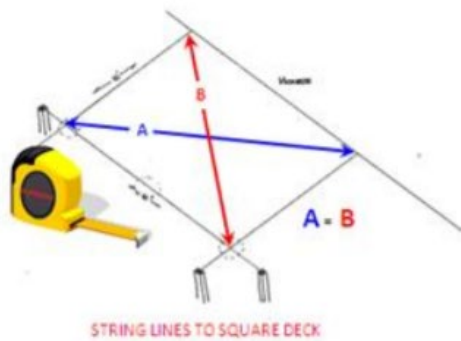

### ANCHORING POST BASE

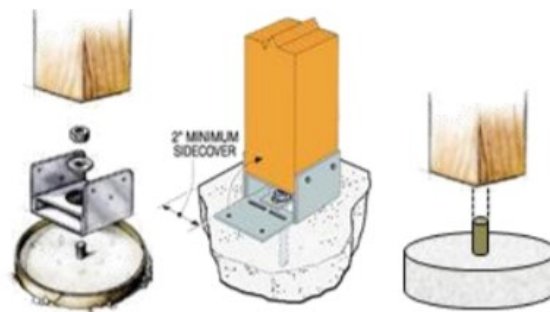

## DECK FRAMING

Make sure the ledger is securely attached to the dwelling. Install metal flashing at top and caulk sides.

TABLE R507.9.1.3(1)  
DECK LEDGER CONNECTION TO BAND JOIST<sup>a, b</sup> (Deck live load = 40 psf, deck dead load = 10 psf, snow load ≤ 40 psf)

CONNECTION DETAILS	JOIST SPAN						
	6' and less	6'1" to 8'	8'1" to 10'	10'1" to 12'	12'1" to 14'	14'1" to 16'	16'1" to 18'
	On-center spacing of fasteners						
1/2-inch diameter lag screw with 1/2-inch maximum sheathing <sup>c, d</sup>	30	23	18	15	13	11	10
1/2-inch diameter bolt with 1/2-inch maximum sheathing <sup>d</sup>	36	36	34	29	24	21	19
1/2-inch diameter bolt with 1-inch maximum sheathing <sup>e</sup>	36	36	29	24	21	18	16

For SI: 1 inch = 25.4 mm, 1 foot = 304.8 mm, 1 pound per square foot = 0.0479 kPa.

- Ledgers shall be flashed in accordance with Section R703.4 to prevent water from contacting the house band joist.
- Snow load shall not be assumed to act concurrently with live load.
- The tip of the lag screw shall fully extend beyond the inside face of the band joist.
- Sheathing shall be wood structural panel or solid sawn lumber.
- Sheathing shall be permitted to be wood structural panel, gypsum board, fiberboard, lumber or foam sheathing. Up to 1/2-inch thickness of stacked washers shall be permitted to substitute for up to 1/2 inch of allowable sheathing thickness where combined with wood structural panel or lumber sheathing.

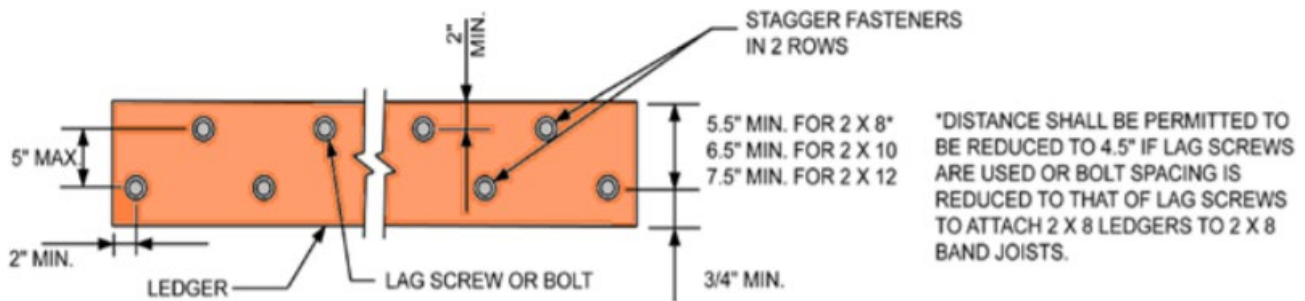

TABLE R507.9.1.3(2)  
PLACEMENT OF LAG SCREWS AND BOLTS IN DECK LEDGERS AND BAND JOISTS

	MINIMUM END AND EDGE DISTANCES AND SPACING BETWEEN ROWS			
	TOP EDGE	BOTTOM EDGE	ENDS	ROW SPACING
Ledger <sup>a</sup>	2 inches <sup>d</sup>	3/4 inch	2 inches <sup>b</sup>	1 5/8 inches <sup>b</sup>
Band Joist <sup>c</sup>	3/4 inch	2 inches	2 inches <sup>b</sup>	1 5/8 inches <sup>b</sup>

For SI: 1 inch = 25.4 mm.

- Lag screws or bolts shall be staggered from the top to the bottom along the horizontal run of the deck ledger in accordance with Figure R507.9.1.3(1).
- Maximum 5 inches.
- For engineered rim joists, the manufacturer's recommendations shall govern.
- The minimum distance from bottom row of lag screws or bolts to the top edge of the ledger shall be in accordance with Figure R507.9.1.3(1).

## PLACEMENT OF LAG SCREWS AND BOLTS IN BAND JOISTS

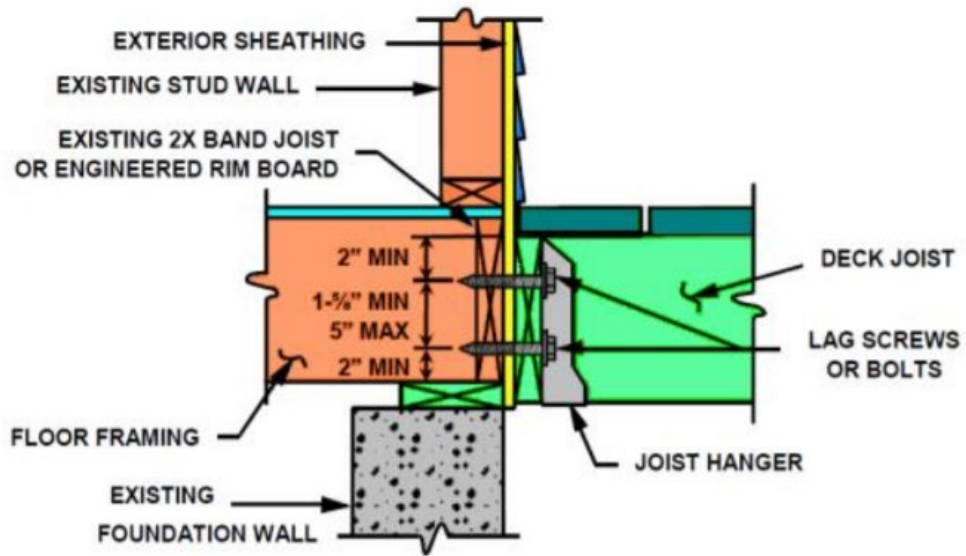

### $\frac{1}{2}$ " DIAMETER LAG SCREWS MINIMUM

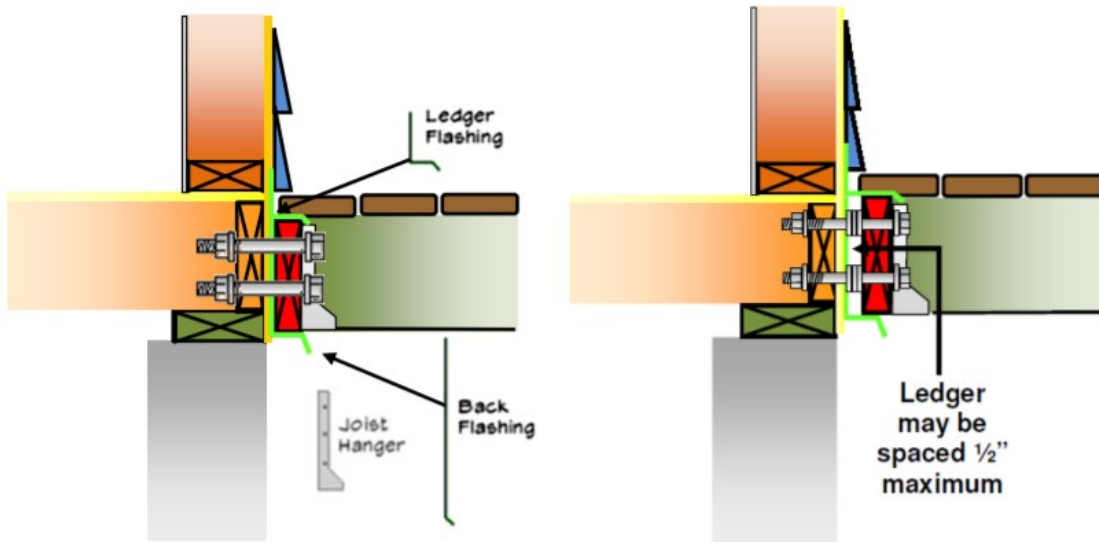
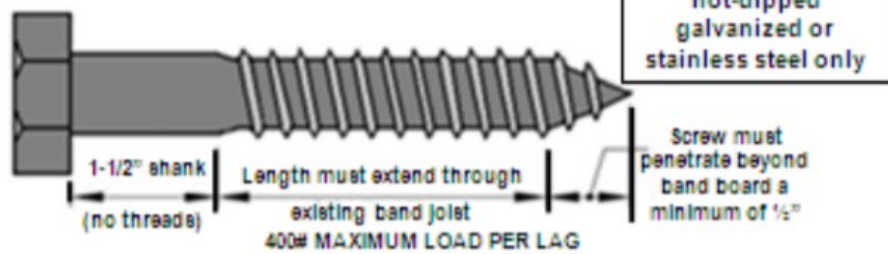

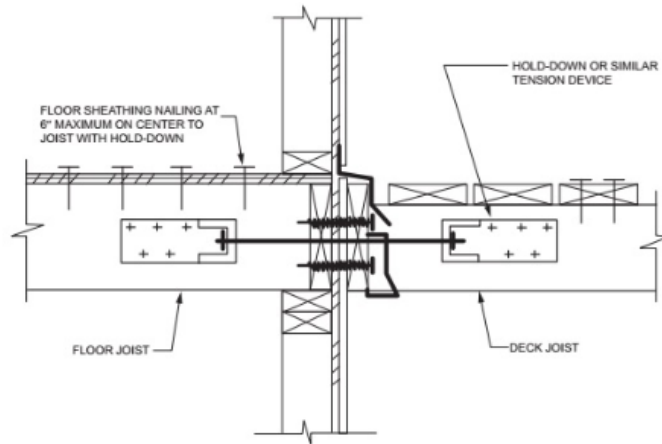

For SI: 1 inch = 25.4 mm.

FIGURE R507.9.2(1)  
DECK ATTACHMENT FOR LATERAL LOADS

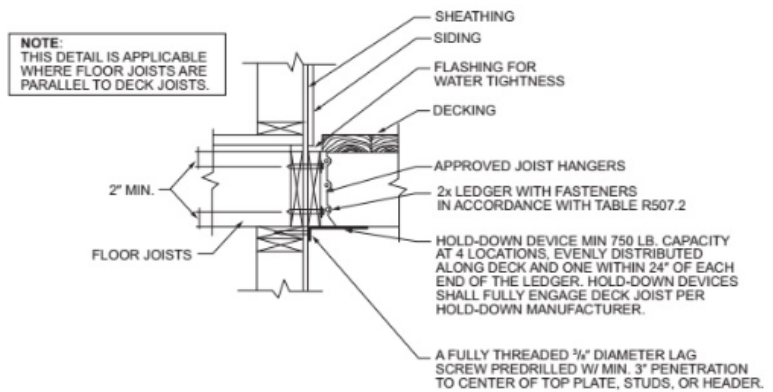

For SI: 1 inch = 25.4 mm, 1 foot = 304.8 mm.

FIGURE R507.9.2(2)  
DECK ATTACHMENT FOR LATERAL LOADS



## BEAMS

Construct beams using two or more 2 inch nominal pieces of lumber. Nail beams together using 16d nails at 16 inches o.c. along each edge of the beam. A spacer may be used to fir the beam to a 3½ -inch width. Beams should be installed with any arch or crown facing up. Attachments to columns should be with post caps designed for such use. Splices must occur over columns.

<b>BEAM SPANS (Wet Service)</b> (Center of one column to center of next) (Source AF&PA; rev. 8-17-10)								
Species	Beam Size	Joist Spans						
		6'	8'	10'	12'	14'	16'	18'
Southern Pine	2-2X6	7'1"	6'2"	5'6"	5'0"	4'8"	4'4"	4'1"
	2-2X8	9'2"	7'11"	7'1"	6'6"	6'0"	5'7"	5'3"
	2-2X10	11'10"	10'3"	9'2"	8'5"	7'9"	7'3"	6'10"
	2-2X12	13'11"	12'0"	10'9"	9'10"	9'1"	8'6"	8'0"
	3-2X6	8'7"	7'8"	6'11"	6'3"	5'10"	5'5"	5'2"
	3-2X8	11'4"	9'11"	8'11"	8'1"	7'6"	7'0"	6'7"
	3-2X10	14'5"	12'10"	11'6"	10'6"	9'9"	9'1"	8'7"
	3-2X12	17'5"	15'1"	13'6"	12'4"	11'5"	10'8"	10'1"
Cedar, Redwood, Ponderosa Pine	2-2X6	5'5"	4'8"	4'2"	3'10"	3'6"	3'1"	2'9"
	2-2X8	6'10"	5'11"	5'4"	4'10"	4'6"	4'1"	3'8"
	2-2X10	8'4"	7'3"	6'6"	5'11"	5'6"	5'1"	4'8"
	2-2X12	9'8"	8'5"	7'6"	6'10"	6'4"	5'11"	5'7"
	3-2X6	7'4"	6'8"	6'0"	5'6"	5'1"	4'9"	4'6"
	3-2X8	9'8"	8'6"	7'7"	6'11"	6'5"	6'0"	5'8"
	3-2X10	12'0"	10'5"	9'4"	8'6"	7'10"	7'4"	6'11"
	3-2X12	13'11"	12'1"	10'9"	9'10"	9'1"	8'6"	8'1"

METHODS OF ATTACHING BEAM TO COLUMN

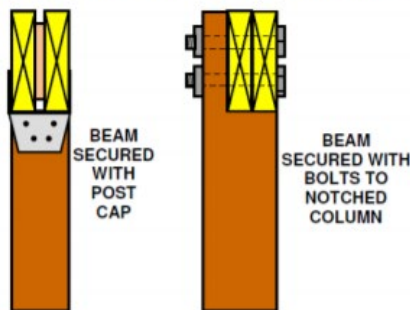

BEAM SPLICES

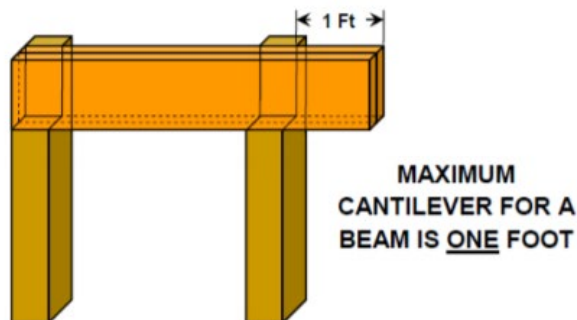
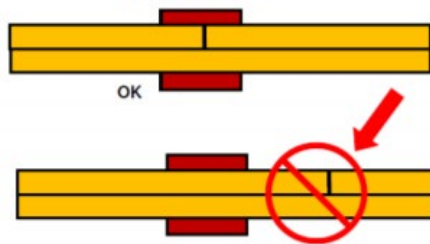

# COLUMNS

TABLE R507.4  
DECK POST HEIGHT<sup>a</sup>

DECK POST SIZE	MAXIMUM HEIGHT <sup>a, b</sup> (feet-inches)
4 x 4	6-9 <sup>c</sup>
4 x 6	8
6 x 6	14
8 x 8	14

For SI: 1 inch = 25.4 mm, 1 foot = 304.8 mm, 1 pound per square foot = 0.0479 kPa.

a. Measured to the underside of the beam.

b. Based on 40 psf live load.

c. The maximum permitted height is 8 feet for one-ply and two-ply beams. The maximum permitted height for three-ply beams on post cap is 6 feet 9 inches.

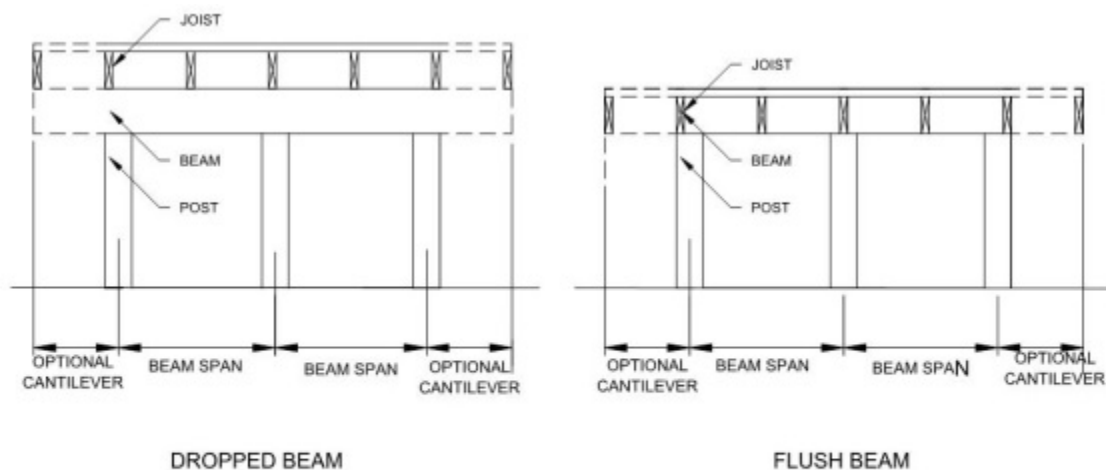
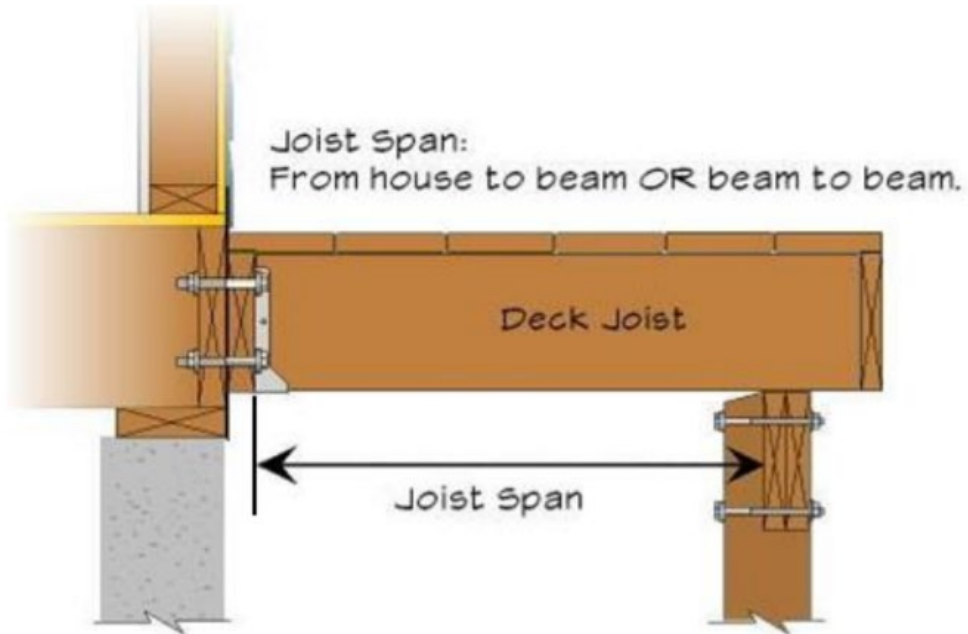

FIGURE R507.5  
TYPICAL DECK JOIST SPANS

TABLE R507.6  
DECK JOIST SPANS FOR COMMON LUMBER SPECIES (ft. - in.)

SPECIES <sup>a</sup>	SIZE	ALLOWABLE JOIST SPAN <sup>b</sup>			MAXIMUM CANTILEVER <sup>c, f</sup>		
		SPACING OF DECK JOISTS (inches)			SPACING OF DECK JOISTS WITH CANTILEVERS <sup>c</sup> (inches)		
		12	16	24	12	16	24
Southern pine	2 x 6	9-11	9-0	7-7	1-3	1-4	1-6
	2 x 8	13-1	11-10	9-8	2-1	2-3	2-5
	2 x 10	16-2	14-0	11-5	3-4	3-6	2-10
	2 x 12	18-0	16-6	13-6	4-6	4-2	3-4
Douglas fir-larch <sup>d</sup> , hem-fir <sup>d</sup> , spruce-pine-fir <sup>d</sup>	2 x 6	9-6	8-8	7-2	1-2	1-3	1-5
	2 x 8	12-6	11-1	9-1	1-11	2-1	2-3
	2 x 10	15-8	13-7	11-1	3-1	3-5	2-9
	2 x 12	18-0	15-9	12-10	4-6	3-11	3-3
Redwood, western cedars, ponderosa pine <sup>e</sup> , red pine <sup>e</sup>	2 x 6	8-10	8-0	7-0	1-0	1-1	1-2
	2 x 8	11-8	10-7	8-8	1-8	1-10	2-0
	2 x 10	14-11	13-0	10-7	2-8	2-10	2-8
	2 x 12	17-5	15-1	12-4	3-10	3-9	3-1



## JOIST DETAILS

JOIST SPACING IS DETERMINED BY THE TYPE OF DECKING USED. 16" O.C. SPACING MUST BE USED WITH 5/4 DECKING OR WHEN 2X6 OR 2X4 DECKING IS USED AT A 45° ANGLE. 12" O.C. SPACING REQUIRED WHEN 5/4 DECKING IS USED AT A 45° ANGLE.

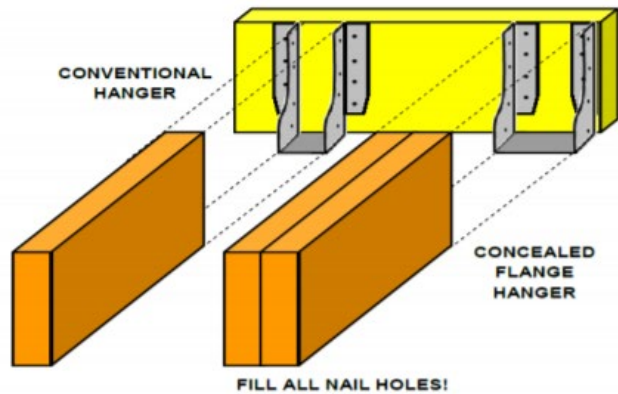
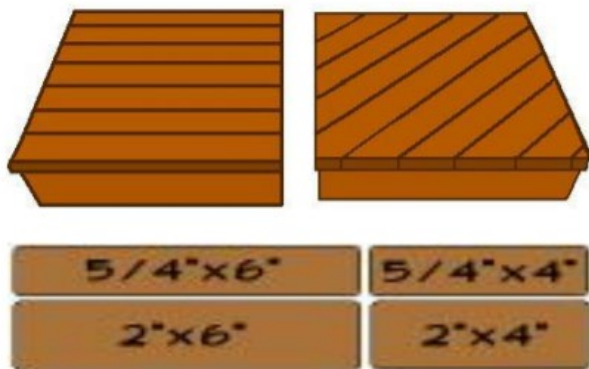
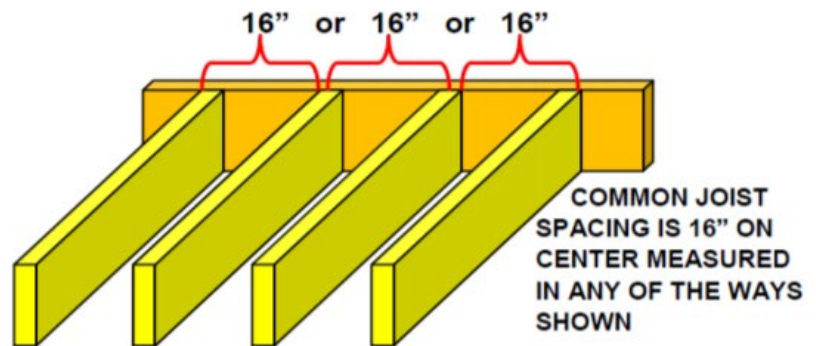

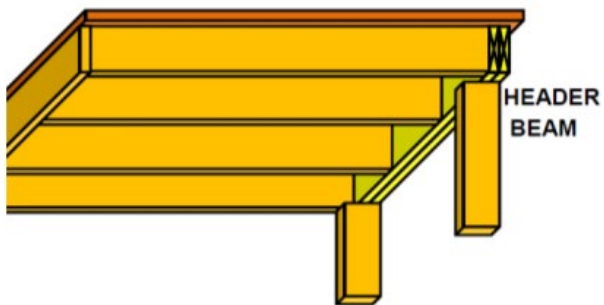
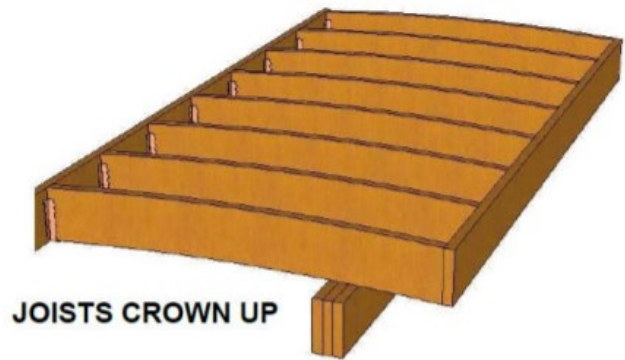
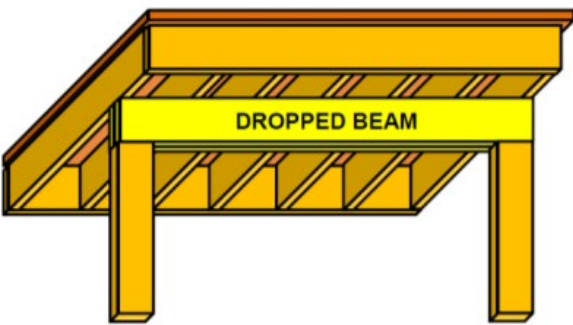
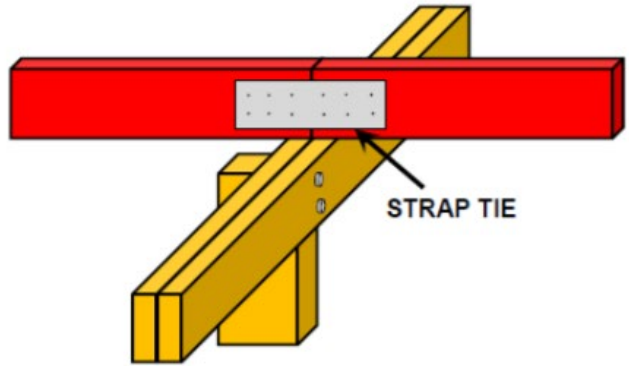
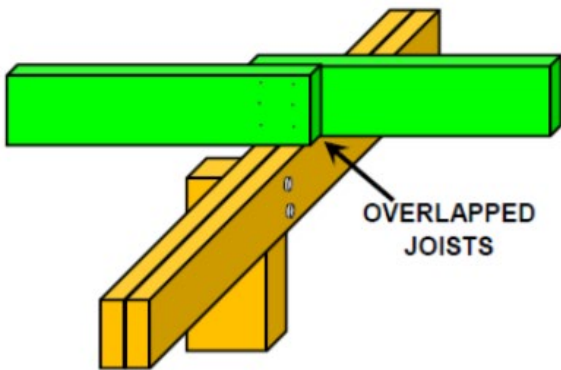

### JOIST TO BEAM ATTACHMENTS

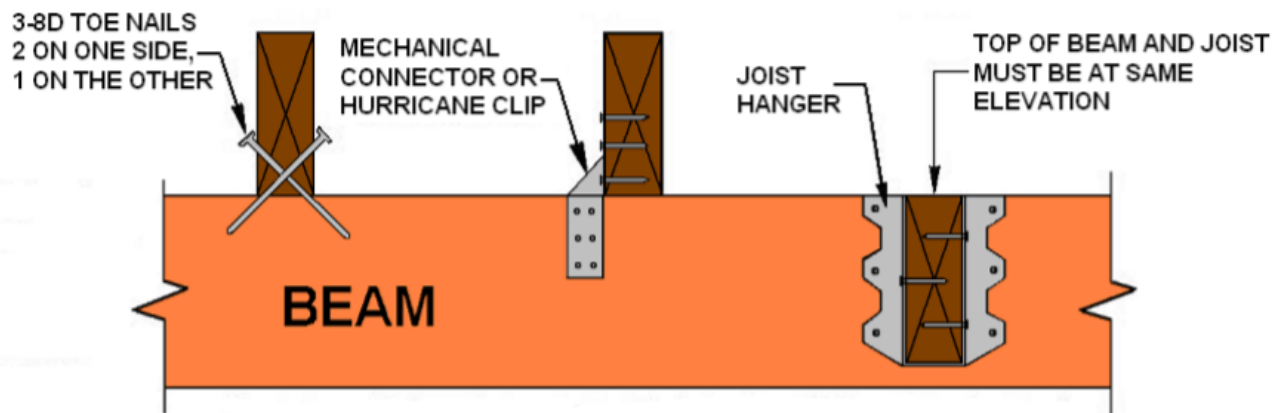

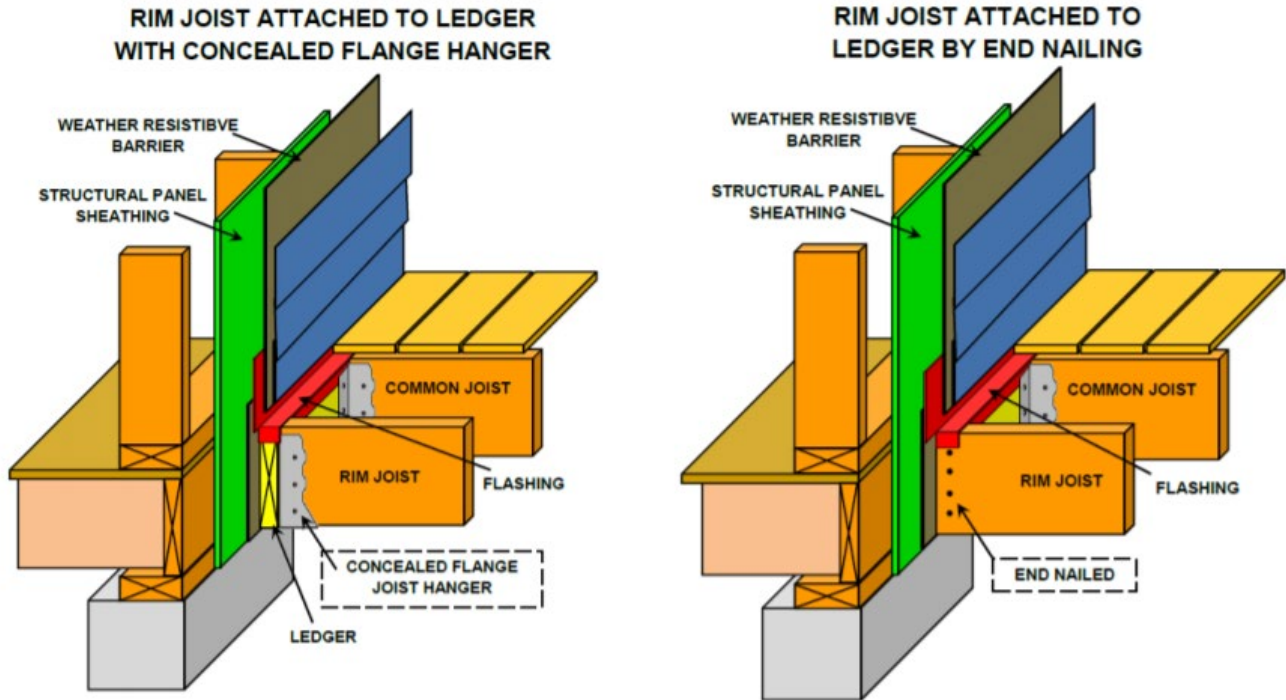

MAXIMUM CANTILEVER SPANS FOR JOISTS WITH BACKSPAN AT LEAST 2:1		
JOIST SIZE	SPACING O.C.	MAX. CANTILEVER
2X8	12"	39"
2X8	16"	34"
2X10	12"	57"
2X10	16"	49"
2X10	24"	40"
2X12	16"	67"
2X12	24"	54"

Joists must bear on a beam, ledger strip, or joist hangers. Joist hangers must be installed in accordance with the manufacturer's recommendations. **Fill all nail holes in joist hangers.**

## CANTILEVERS

THE AMOUNT OF CANTILEVER IS LIMITED BY THE SIZE AND SPACING OF THE JOIST AND THE LENGTH OF THE BACKSPAN

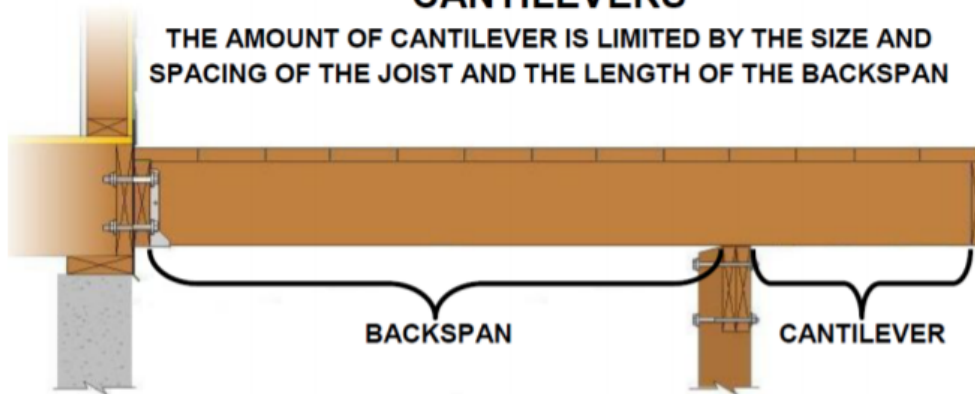



# HOUSE CANTILEVERS

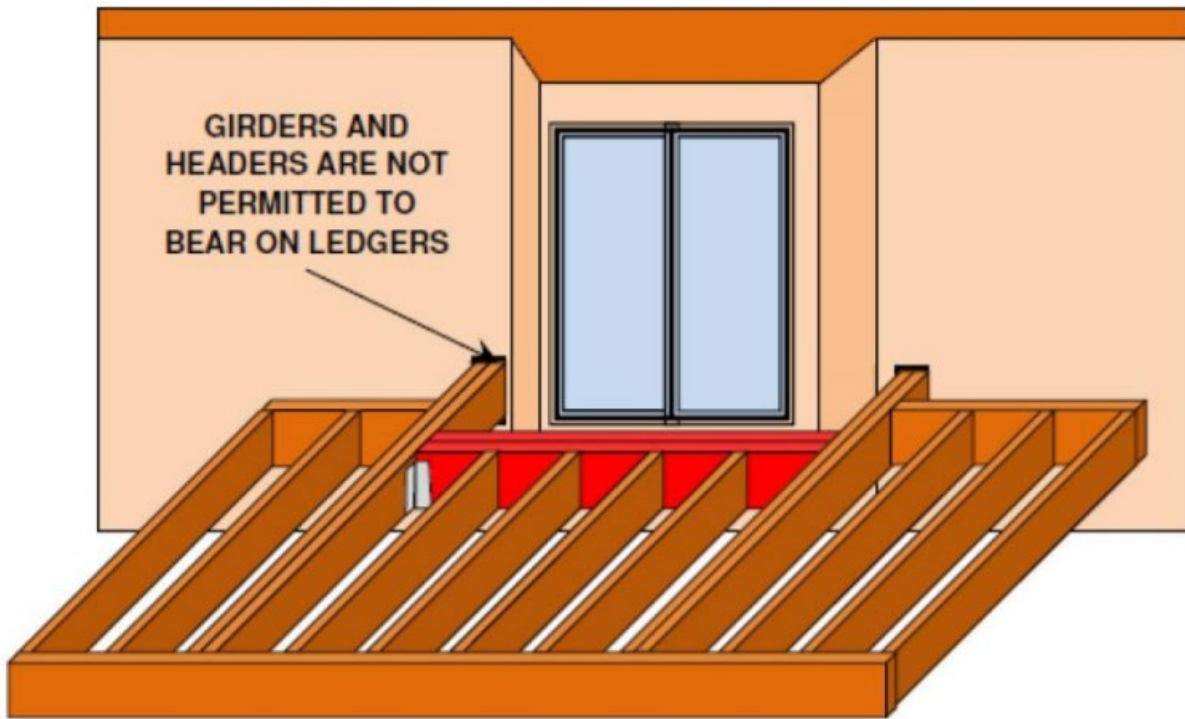

# SPECIAL FLOOR FRAMING DETAILS

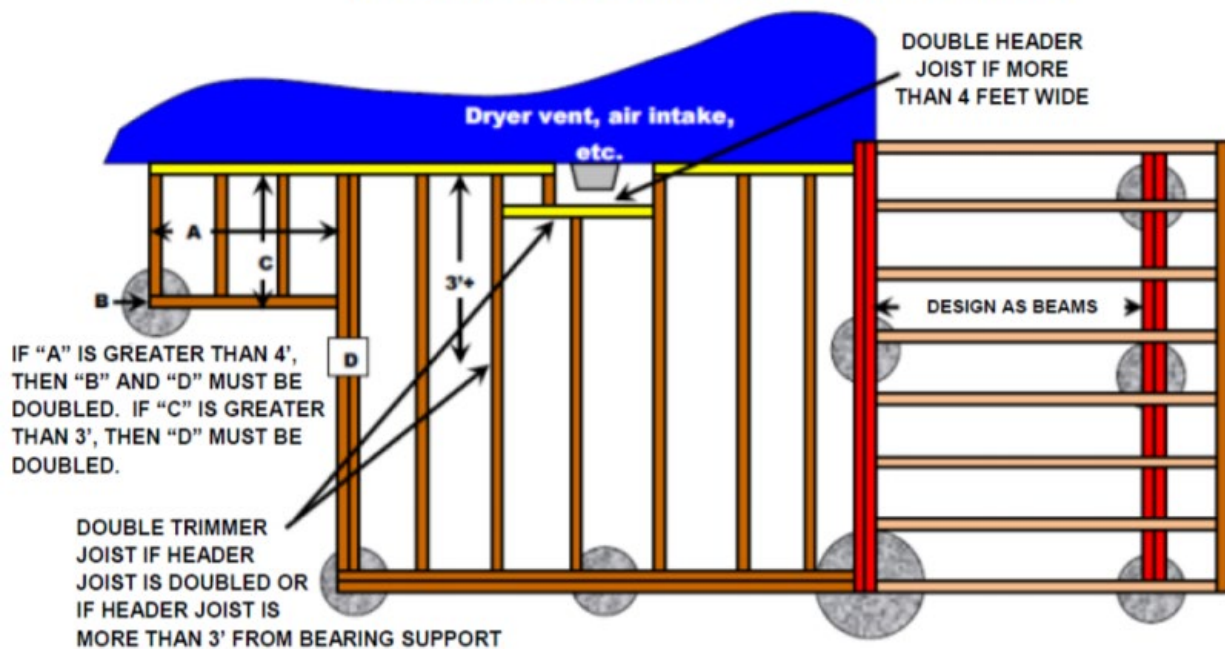

## DECK ATTACHMENTS TO I-JOIST OR TRUSS FLOOR SYSTEMS

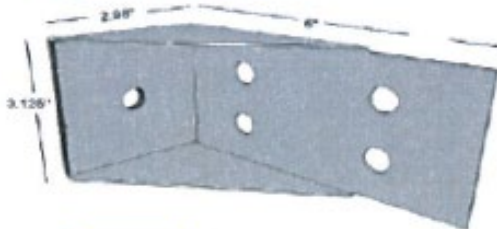
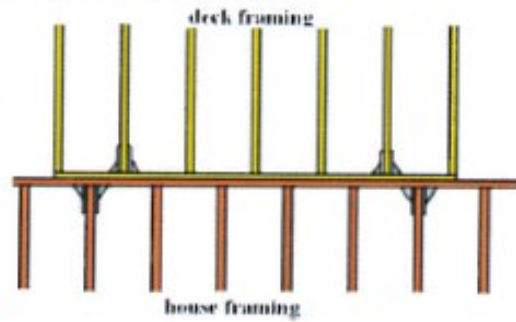
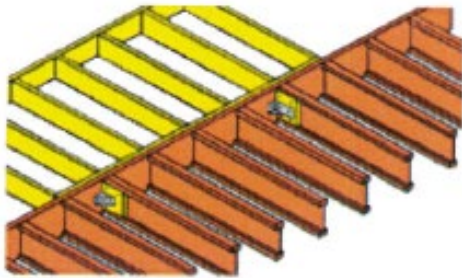

**INSTALL CONNECTOR IN ACCORDANCE WITH MANUFACTURERE'S INSTALLATION INSTRUCTIONS**

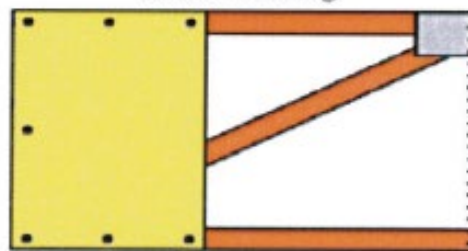
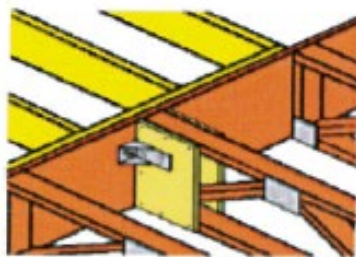
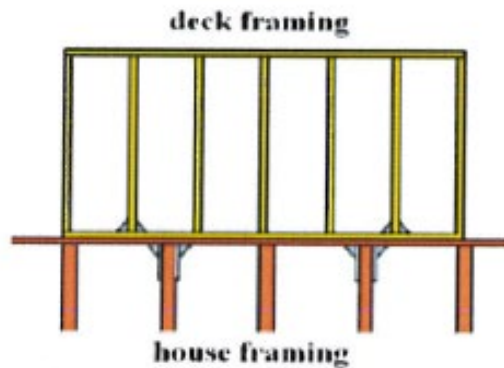
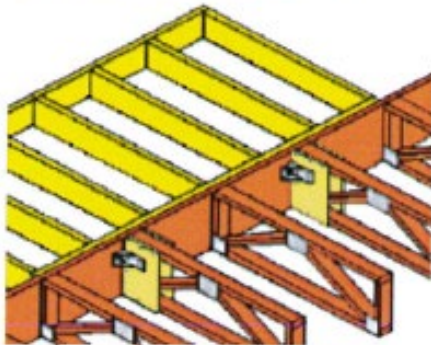
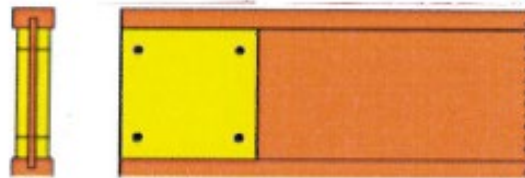
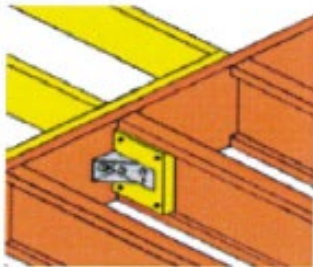

**truss joist to rim joist & ledger**

**blocking plate nailed to truss joist**

## STAIRS

Stairs must have a maximum rise of 8 1/4 inches and a minimum run of 9 inches measured as shown. The greatest riser height within any flight of stairs shall not exceed the smallest by more than 3/8 inch. The greatest tread depth within any flight of stairs shall not exceed the smallest by more than 3/8 inch. Open risers are permitted provided that a 4" diameter sphere will not pass between the treads.

Stairs must be a minimum of 36 inches wide above the handrail and 31 1/2 inches below the handrail.

### STAIR TERMINOLOGY

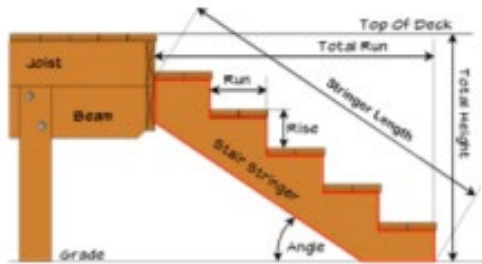

Stair Basics

- The maximum riser height is 7 3/4 inches
- The minimum tread run is 10 inches
- Treads and risers should be approximately equal with the largest not exceeding the smallest by more than 3/8 inch.

### DETERMINING RISE/RUN

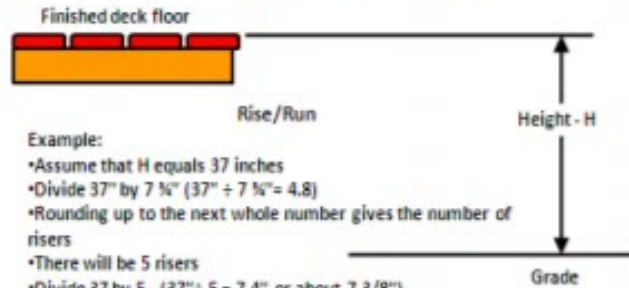

Example:

- Assume that H equals 37 inches
- Divide 37" by 7 3/4" (37" ÷ 7 3/4" = 4.8)
- Rounding up to the next whole number gives the number of risers
- There will be 5 risers
- Divide 37 by 5. (37" ÷ 5 = 7.4" or about 7 3/8")
- Each riser will be 7 3/8"
- For 5 risers there will be 4 treads
- Since each tread must be at least 10", the length of the stair from the face of the deck to the face of the bottom riser will be at least 40" (10" X 4 treads = 40")

### LAYING OUT STAIR JACKS

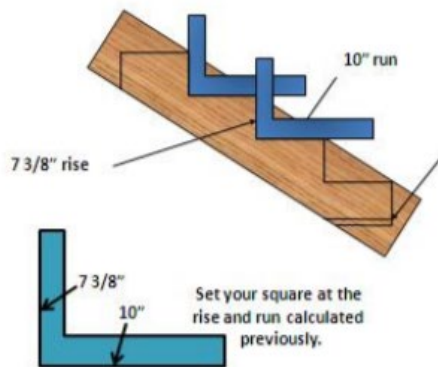

Cut an amount equal to the thickness of the tread from the bottom of the stair jack

Set your square at the rise and run calculated previously.

### THE COMPLETED STAIR

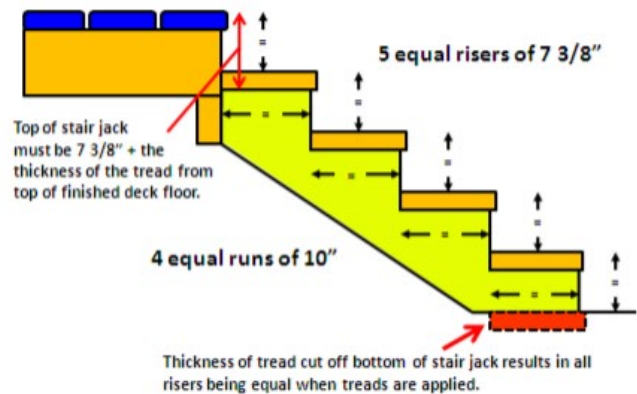

Thickness of tread cut off bottom of stair jack results in all risers being equal when treads are applied.

DIAGRAMS ARE FOR INFORMATIONAL PURPOSES ONLY (INDIANA CODE REQUIRES 8 1/4 MAXIMUM RISE AND 9" TREADS MINIMUM)



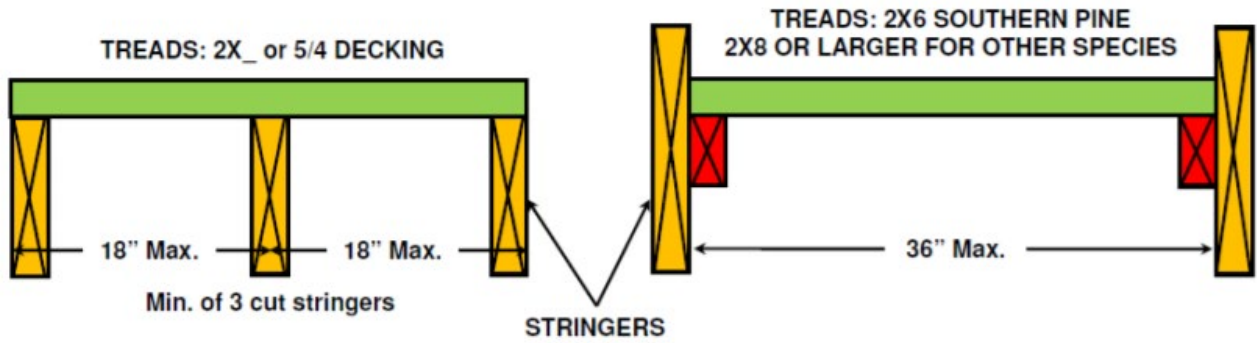

## STAIR STRINGER SPANS

LANDINGS OR COLUMNS AND BEAMS MAY BE USED TO SHORTEN STRINGER SPANS

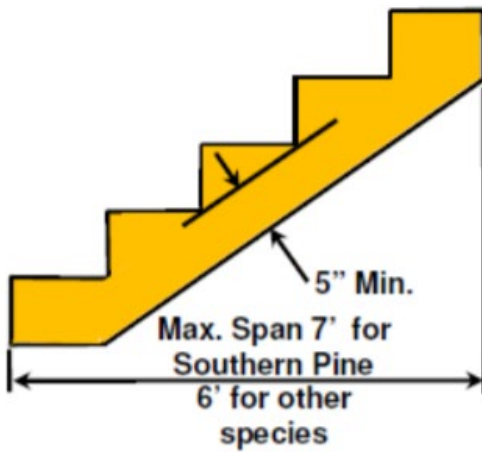

CUT STRINGER

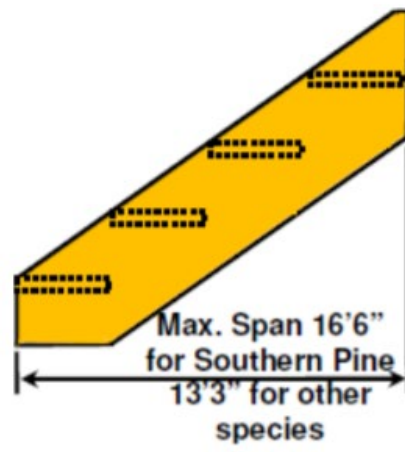

SOLID STRINGER

# STAIR ATTACHMENTS

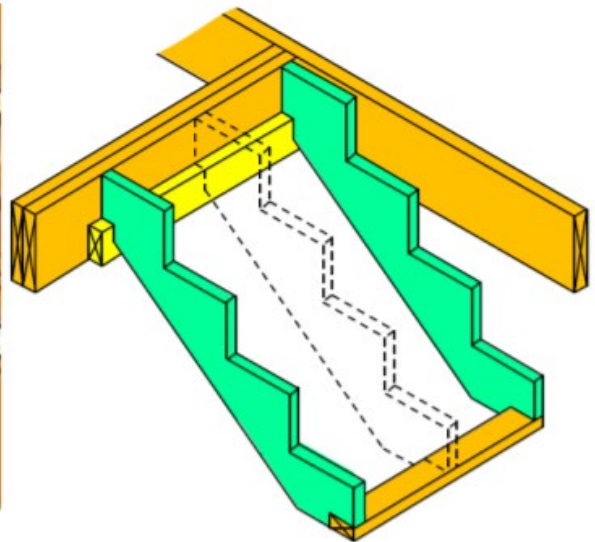
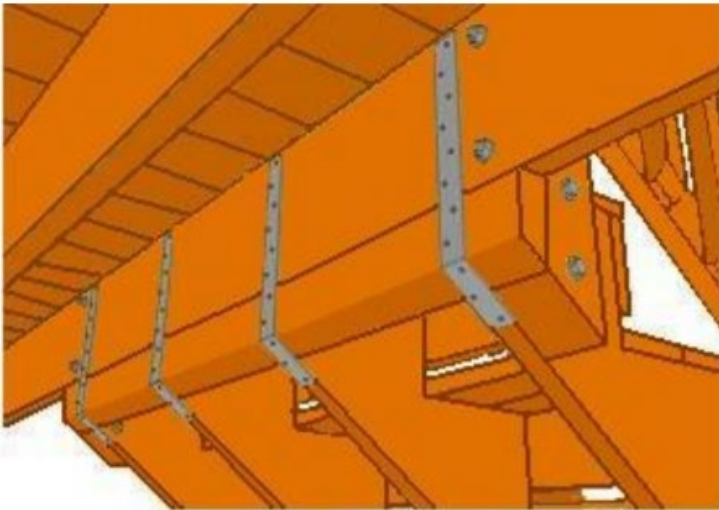
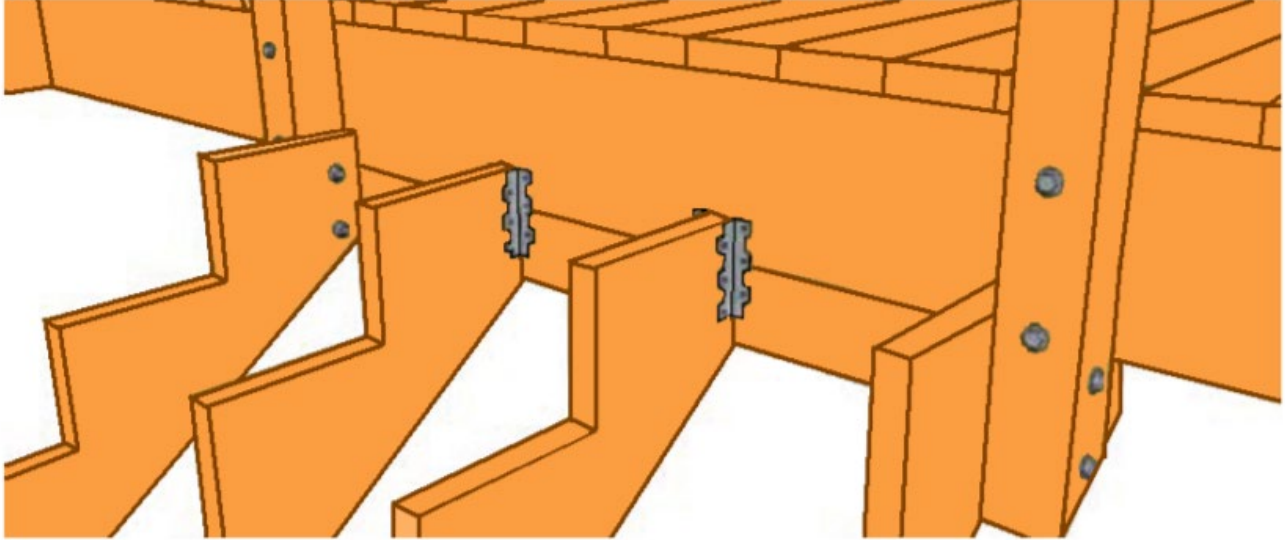



## GUARDS AND HANDRAILS

Guards and handrails must be provided as shown on the following illustrations. Guards must continue down stairs where the stair is more than 30 inches above grade. The height of guards on stairs must be 34 inches minimum.

***Handrails must be provided on at least one side when there are four or more risers.***

***Handrails must have returns on each end or terminate in a newel post.*** Other handrail shapes having an equivalent gripping shape may be used with prior approval of the Building Department.

***Handrails must be continuous for the entire length of the stairs and may not be interrupted by newel posts except at landings.***

**Hand rails and guards must be designed to support a 200 lb load applied in any direction at any point along the top of the guard or rail.** The bottoms of the stringers should rest on a sound foundation such as a gravel bed, a concrete pad, pavers, or similar.

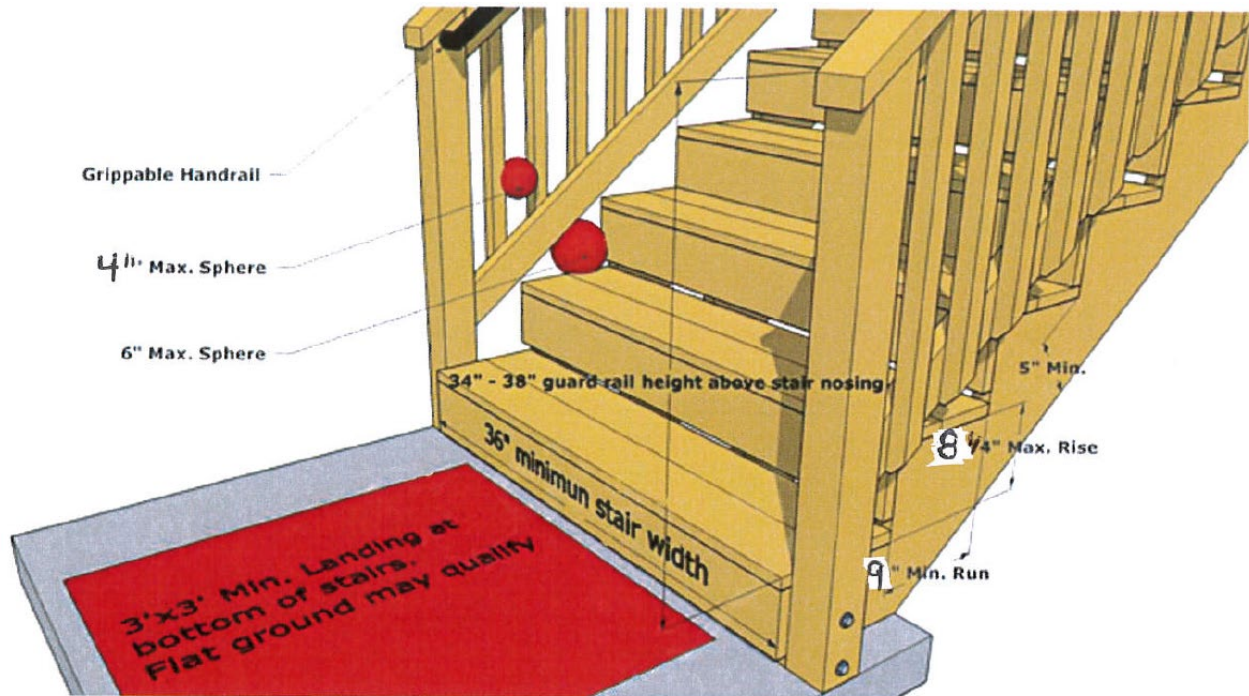

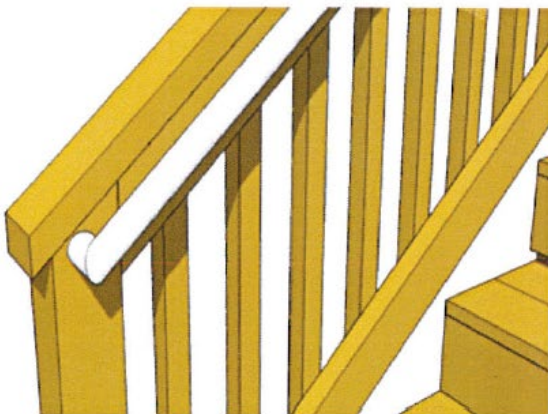
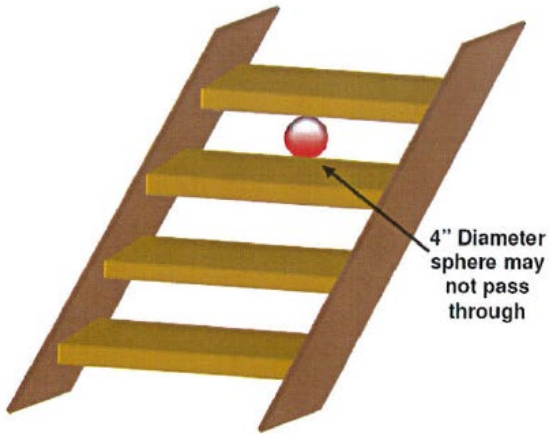
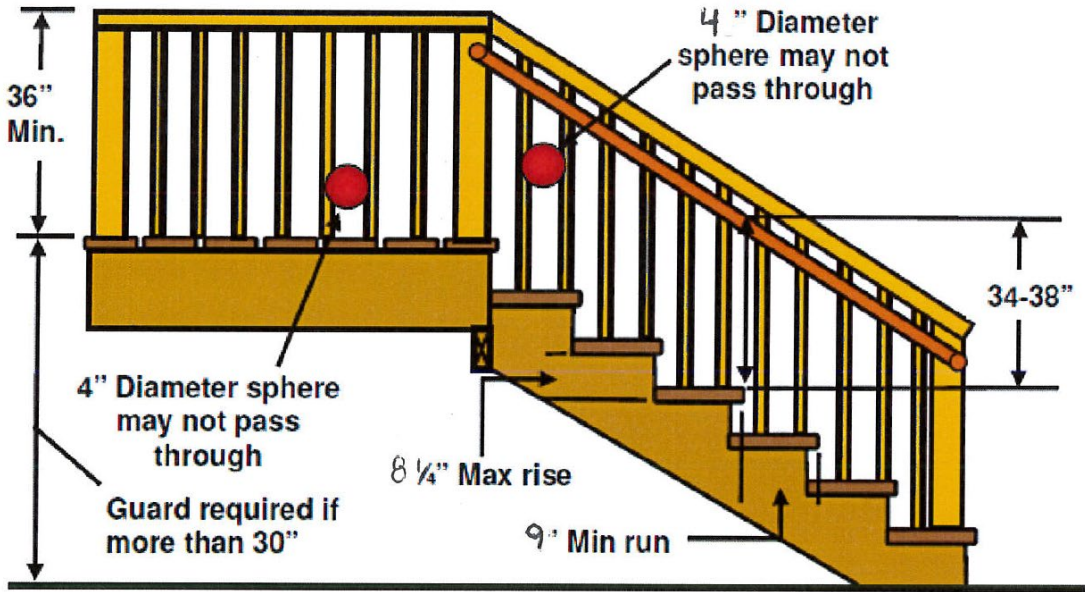

HANDRAILS MUST RETURN TO A NEWEL POST AND BE CONTINUOUS WITHOUT INTERRUPTION FOR THE LENGTH OF THE FLIGHT

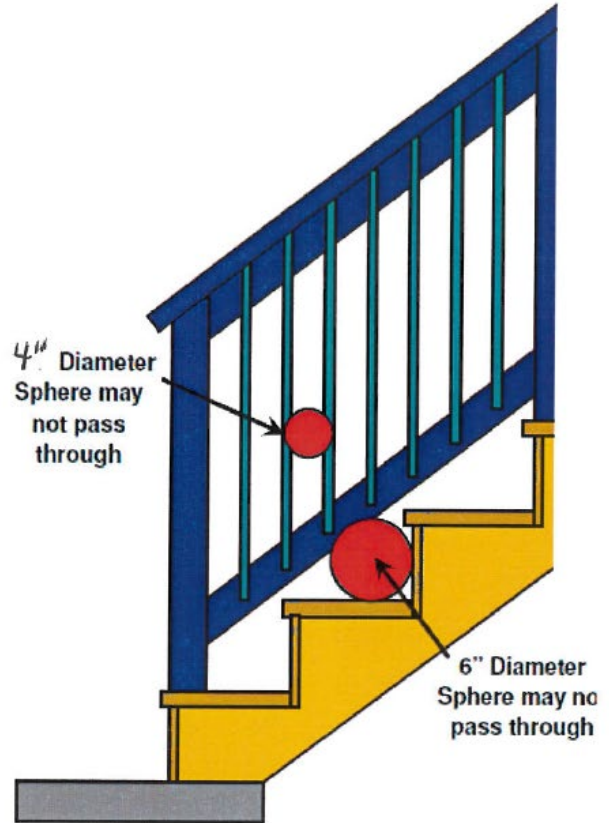

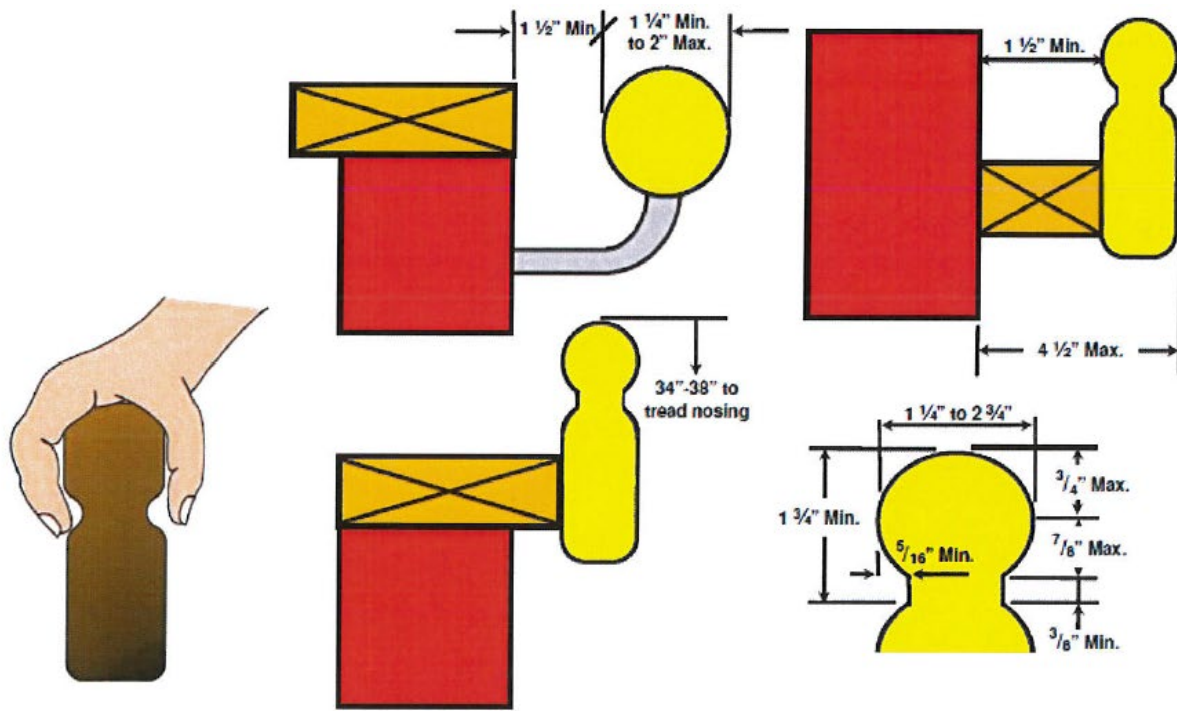



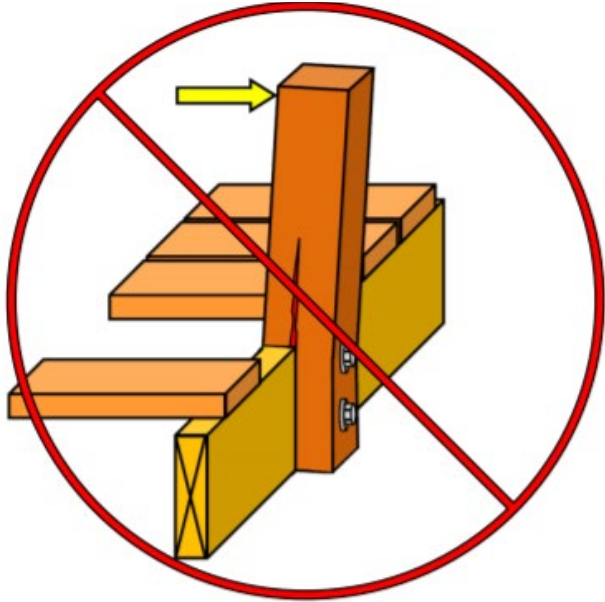
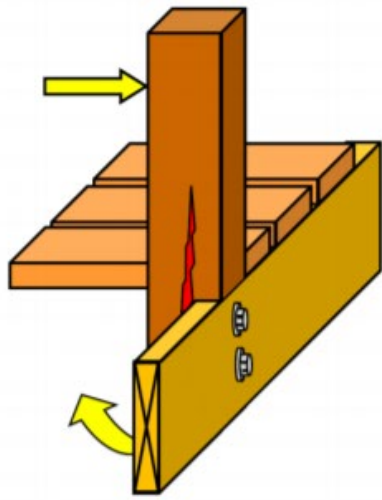

**AVOID NOTCHING  
GUARD POSTS**

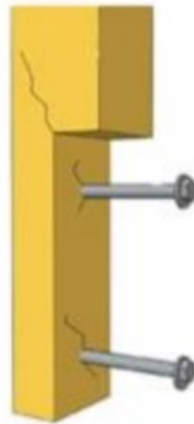
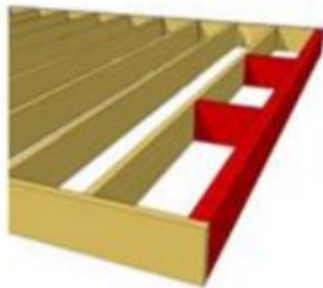

**BLOCKING MAY BE ADDED TO  
STRENGTHEN POST ATTACHMENT**

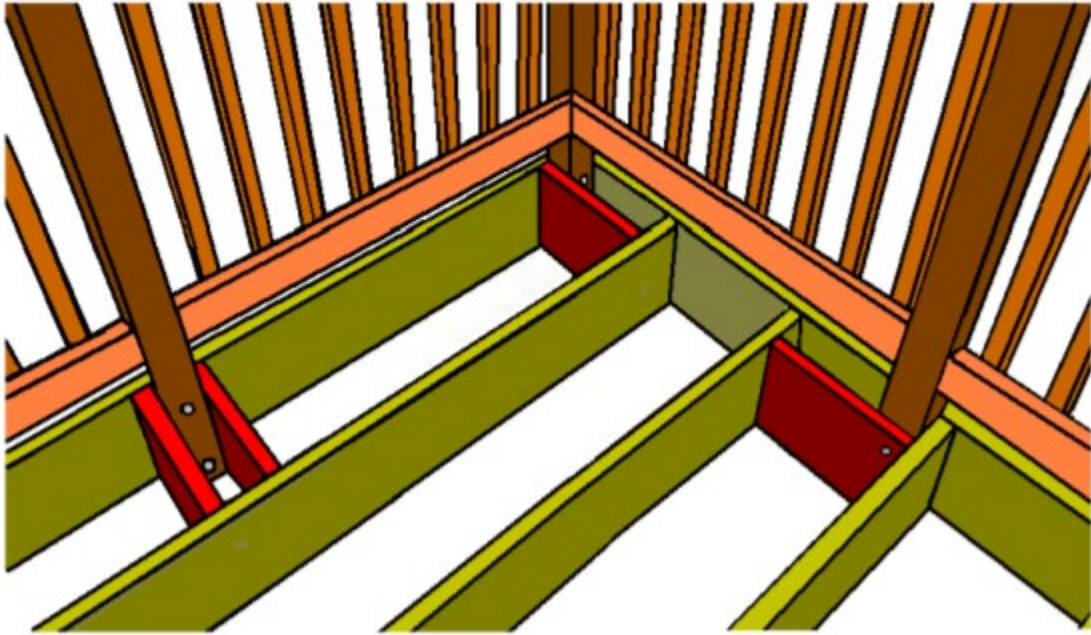

**Examples of Devices that can be  
used to resist horizontal loads**

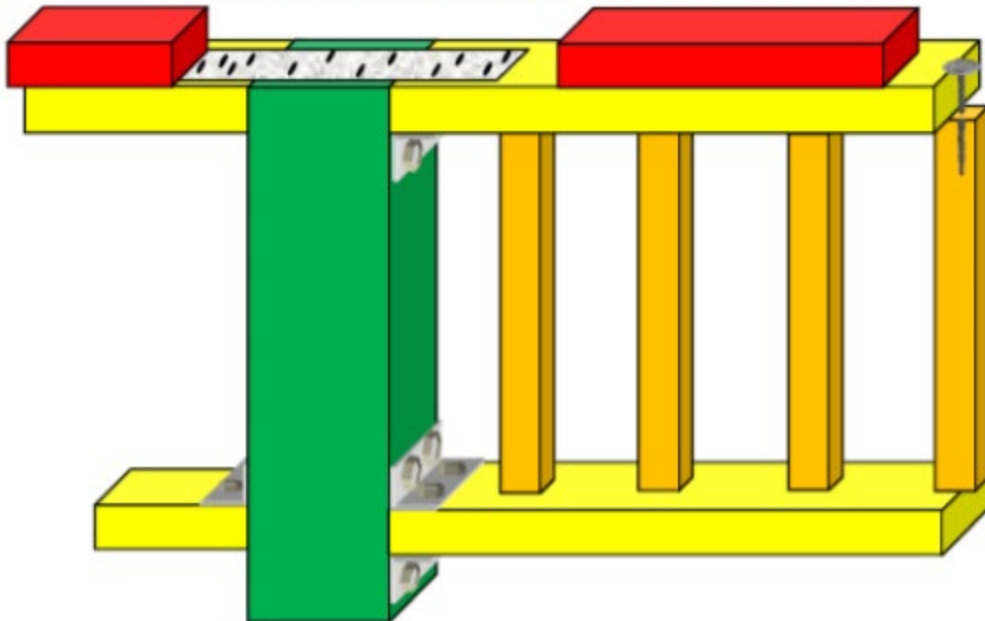



---

## **COMPOSITES AND OTHER DECK/RAILING PRODUCTS**

**THIS HANDOUT DOES NOT COVER DECK OR RAILING PRODUCTS MADE OF COMPSITES, ALUMINUM, STEEL, GLASS, OR ANY OTHER MAN MADE PRODUCT. THOSE PRODUCTS MAY BE USED IF THE MANUFACTURER HAS A RESEARCH REPORT FROM THE INTERNATIONAL CODE COUNCIL AND THE PRODUCT IS INSTALLED IN STRICT ACCORDANCE WITH THAT REPORT.**

# CHECKLIST FOR DECK PLANS

## Site Plan

- Street address and/or legal description shown
- North arrow shown
- Plan drawn to useable scale and scale used shown
- Size of existing buildings shown
- All lot dimensions and pin locations shown
- Location and size of proposed deck shown
- Distance to all lot lines from existing buildings and proposed deck

## Construction Plans

- Plans drawn to useable scale
- Scale indicated on plan
- Plan neat and legible

## Elevation (This could be illustrated on section drawings)

- Show side and front view of deck in relation to grade and dwelling
- Include railing height and design

## Framing Plan

- Floor joist size and spacing including species and grade
- Orientation of floor joists
- Cantilever of joists
- Bearing points for all joists
- Size and location of all beams including species and grade
- Cantilever of beams
- Size and location of ledger board including species and grade
- Size and location of all columns including species and grade
- Track all floor loads thru beams to columns to footings
- Location of stairs
- Changes in elevation of deck floors or landings
- Unusual framing issues such as cantilevers of the dwelling floor

## Ledger Details

- Framing method and orientation of existing dwelling floor framing.
- Method of meeting lateral load connection requirements
- Spacing, location, and type of bolts or lags used to attach ledger.

## Footings (This information may be included on section or framing plans)

- Footing depth and design
- Footing width at base consistent with load for each footing location.

## Section(s)

- Section view(s) from bottom of footing to top of guard to show railing details; floor framing orientation; joist/beam orientation and bearing; column locations; connections; footing design, size, and depth; and height of deck floor above grade.

## Details

- Flashing at the ledger
- Joist bearing/hangers
- Ledger connection (Caution for dwelling floor cantilevers)
- Fasteners/connectors consistent with lumber and decking used
- Column/beam connection
- Column/footing connection
- Type of decking and orientation (Caution for 5/4 or composite decking for spans more than 16" o.c. or installed diagonally)
- Research report required for decking other than wood
- Stair stringer connection
- Lateral bracing

## Stairs

- Width of stairs
- Rise/run w/tolerance shown
- Number and size of stringers
- Open riser design
- Type and size of tread consistent with stringer spacing (Caution for decking use)
- Connection method for treads to stringers
- Handrails shown for stairs with 4 or more risers
- Handrail height shown on plan
- Handrail profile detailed
- Landing at bottom of stair
- Show any doors or windows adjacent stairs and landings.

## Guards

- Guard height and opening dimensions
- Guard design/materials
- Guard attachment

Date: \_\_\_\_\_

Job Address: \_\_\_\_\_